



Standard Safety Specification for Components, Assembly, Use, and Labeling of Consumer Trampolines¹

This standard is issued under the fixed designation F381; the number immediately following the designation indicates the year of original adoption or, in the case of revision, the year of last revision. A number in parentheses indicates the year of last reapproval. A superscript epsilon (ε) indicates an editorial change since the last revision or reapproval.

1. Scope

1.1 This safety specification covers the components, the assembly, and the use of consumer trampolines.

1.2 This specification is delimited in its application to trampolines of (1) a minimum bed size of 3300 in.² (21 300 cm²), (2) a minimum height of 20 in. (51 cm), (3) intended for the purpose of continuous, vertical jumping activities and (4) intended for consumer use.

1.3 This specification is intended (1) to reduce the demonstrated hazards associated with the use of trampolines by consumers; (2) for trampolines used in a home environment by a single user; and (3) not to apply to institutional trampolines or trampolines intended for use on water. Trampolines that adhere to this specification are not recommended for use by children under six years of age.

1.4 The values stated in inch-pound units are to be regarded as standard. The values given in parentheses are mathematical conversions to SI units that are provided for information only and are not considered standard.

1.5 *This standard does not purport to address all of the hazards associated with trampolines. The standard's existence alone will not necessarily prevent injuries. Like other physical activities, trampoline use involves the risk of injury, particularly if the equipment is used improperly.*

1.6 *This standard does not purport to address all of the safety concerns, if any, associated with its use. It is the responsibility of the user of this standard to establish appropriate safety and health practices and determine the applicability of regulatory limitations prior to use.*

1.7 This specification includes the following sections and selected subsections.

Title	Section Number
Scope	1
Referenced Documents	2
Terminology	3

¹ This safety specification is under the jurisdiction of ASTM Committee F08 on Sports Equipment, Playing Surfaces, and Facilities and is the direct responsibility of Subcommittee F08.17 on Trampolines and Related Equipment.

Current edition approved June 1, 2016. Published July 2016. Originally approved in 1974. Last previous edition approved in 2015 as F381 – 15. DOI: 10.1520/F0381-16.

Included Components	4
Materials and Manufacture	5
Design Requirements	5.2
Performance Requirements	5.3
Performance Requirements	6
Shock Attenuation	6.1
Drop Test	6.2
Drop test weight and impactor shape.	6.2.5
Drop test procedure.	6.2.6
Padding Attachment System Strength	6.3
Padding Attachment System Strength Test Procedure	6.3.1
Drop Test for Trampoline Edge Survivability	6.4
Drop Test Procedure for Trampolines Where Frame Padding Is Not Required	6.4.1
Crush and Shear Points	6.5
Ultraviolet (UV) Resistant Materials Test	6.6
Static Load Tests	6.7
Static Load Test on Trampoline Bed	6.7.1
Static Load Test on Trampoline Frame	6.7.2
Procedure for Static Load Tests	6.7.4
Information Packet:	7
Packet Marketing and Contents	7.1
Assembly and Installation Instructions	7.2
Care and Maintenance Instructions	7.3
Warning Information	7.4
Use Instructions	7.5
Product Marking:	8
Identification	8.1
On-Trampoline Warnings	8.2
Instruction Sign	8.3
Packaging and Package Marking	9
Access Devices:	10
Trampoline Ladders	10.1
Ladder Warning	10.2
Keywords	11
Appendix	

2. Referenced Documents

2.1 ASTM Standards:²

- [B117 Practice for Operating Salt Spray \(Fog\) Apparatus](#)
- [D638 Test Method for Tensile Properties of Plastics](#)
- [D2240 Test Method for Rubber Property—Durometer Hardness](#)
- [F355 Test Method for Impact Attenuation of Playing Surface Systems and Materials](#)
- [F1487 Consumer Safety Performance Specification for Playground Equipment for Public Use](#)

² For referenced ASTM standards, visit the ASTM website, www.astm.org, or contact ASTM Customer Service at service@astm.org. For *Annual Book of ASTM Standards* volume information, refer to the standard's Document Summary page on the ASTM website.

F2225 Safety Specification for Consumer Trampoline Enclosures

F2774 Practice for Manufacturing Quality Control of Consumer Trampoline Bed Material

2.2 AATCC Standard:³

AATCC Method 169

2.3 ANSI Standard:⁴

ANSI Z535.4 Product Safety Signs and Labels

2.4 Federal Standards:⁵

16 CFR 1500.48 Technical Requirements for Determining a Sharp Point in Toys and Other Articles Intended for Use by Children Under 8 Years of Age

16 CFR 1500.49 Technical Requirements for Determining a Sharp Metal or Glass Edge in Toys and Other Articles Intended for Use by Children Under 8 Years of Age

3.1.13 *portable*, *adj*—able to be easily moved without disassembly, though usually requiring the assistance of devices such as roller stands. Folding-type trampolines are often intended to be portable.

3.1.14 *roller stand*, *n*—device that is used to assist in rolling/moving a folding-type trampoline frame.

3.1.15 *suspension system*, *n*—bed-supporting system made up of elastic devices that connect the bed to the frame, for example, steel extension springs.

3.1.16 *trampoline*, *n*—rebound device activated by vertical jumping, upon which gymnastics skills and exercises are performed.

3.1.17 *trampoline ladder*, *n*—ladder-like device specifically designed for use with a trampoline and designed to be easily removable.

3. Terminology

3.1 *Definitions of Terms Specific to This Standard:*

3.1.1 *access device*, *n*—device used for access to or egress from a trampoline bed including, but not limited to, trampoline ladders.

3.1.2 *bed*, *n*—flexible surface which the user contacts in the course of bouncing on a trampoline.

3.1.3 *bouncing*, *n*—action considered as normal use of a trampoline consisting of continuous, vertical jumping wherein each landing is in near proximity to the previous landing.

3.1.4 *consumer trampoline*, *n*—trampoline intended for use in a home environment.

3.1.5 *folding-type trampoline*, *n*—trampoline whose frame can be folded when not in use. See *portable*.

3.1.6 *frame*, *n*—framework constructed of rigid supportive materials from which the bed is suspended.

3.1.7 *frame padding*, *n*—shock-attenuating protective device(s) that attaches to the frame to cover the frame and suspension system in the plane of the bed.

3.1.8 *institutional trampoline*, *n*—trampoline intended for use in a commercial or institutional facility.

3.1.9 *ladder*, *n*—see *trampoline ladder*.

3.1.10 *legs*, *n*—the framework constructed of rigid materials which support the frame above the ground or floor.

3.1.11 *mat*, *n*—common, though non-preferred term referring to bed.

3.1.12 *maximum specified user weight*, *n*—maximum weight of a user as specified by the manufacturer.

3.1.12.1 *Discussion*—The manufacturer must ensure the maximum specified user weight meets the requirements of Section 6.

4. Included Components

4.1 When a trampoline is offered for sale, it shall include the following: (1) a frame, (2) a bed, (3) a suspension system, (4) frame padding (where the frame is in the plane of the bed), (5) an enclosure in compliance with Safety Specification F2225, (6) an information packet, and (7) suitable markings.

4.2 When a trampoline is offered for sale, a trampoline ladder shall not be included as a component part or within the same packaging.

4.3 When a portable trampoline is offered for sale, it shall include all of the components in 4.1 plus appropriate roller stands.

4.3.1 For folding-type trampolines, the information in 7.5.1 and 8.3.3 shall also include the following:

4.3.1.1 Use two or more strong people to open and close folding-type trampolines.

5. Materials and Manufacture

5.1 The provisions in Section 5 shall apply to a trampoline assembled as instructed in the owner's manual. All performance tests shall be conducted on a fully assembled trampoline and enclosure (if sold as a unit) unless otherwise directed in the test requirements.

5.2 *Design Requirements:*

5.2.1 The trampoline shall be designed such that no part of the frame or legs can be contacted by the bed while bouncing. All frame and leg assemblies shall be joined or fastened together so that it requires either two distinct motions to separate those parts or tools to remove fasteners, to avoid unintentional separation.

5.2.2 The frame padding shall be of a color which contrasts with the color of the trampoline bed.

5.2.3 The suspension system shall be designed so as to protect the performer from injury due to contact with the sharp ends of the trampoline springs.

5.3 *Performance Requirements:*

5.3.1 The frame padding, where required, shall be designed to remain securely attached to the frame when tested to the requirements of 6.2 and 6.3. All tests shall be conducted at ambient temperatures (nominally $68 \pm 5^\circ\text{F}$ ($20 \pm 3^\circ\text{C}$)).

³ Available from American Association of Textile Chemists and Colorists (AATCC), P.O. Box 12215, Research Triangle Park, NC 27709, <http://www.aatcc.org>.

⁴ Available from American National Standards Institute (ANSI), 25 W. 43rd St., 4th Floor, New York, NY 10036.

⁵ Available from U. S. Government Accountability Office (GAO), 441 G St., NW, Washington, DC 20548, <http://www.gao.gov>.

5.3.2 Materials used in any pad cover, frame padding, cover attachments, tie down(s), and pad seams normally exposed to sunlight shall be made from ultraviolet (UV) resistant materials and meet the performance requirements of 6.6.

5.3.3 Material used in the trampoline mat shall meet the requirements specified in Practice F2774.

5.3.4 Except for necessary seams, the frame padding, where required, shall cover the entire top surface of the frame and be wide enough to completely cover the entire top surface of the suspension system and frame when subjected to the tests specified in 6.2.

5.3.5 All information, instructions, and warnings shall be provided in English in addition to any other formats used, for example, graphical, video, multilingual, etc.

5.3.6 When installed in accordance with the manufacturer’s instructions, fasteners, lock washers, self-locking nuts, or other locking means shall be provided for all nuts and bolts to protect them from unintentional loosening; self-locking nuts must fully engage with the bolt. Hardware in moving joints shall also be secured against unintentional loosening. Any other fastening systems shall comply with the requirement that effective locking requires two separate and distinct motions for release.

5.3.7 There shall be no accessible sharp points or edges on fasteners when tested in accordance with 16 CFR 1500.48 and 16 CFR 1500.49.

5.3.8 Bolt ends projecting beyond the face of the nut shall be free of burrs, sharp points, and sharp edges when tested in accordance with 16 CFR 1500.48 and 16 CFR 1500.49. An accessible bolt end shall not extend more than the diameter of

the bolt beyond the face of a nut when the nut is tightened to a torque between 20 and 25 lbf-in (2.3 to 2.8 N-m).

5.3.9 If the exposed bolt end is not free of burrs, sharp points, or sharp edges, or a combination thereof, then the threaded ends of bolts may be covered by smooth, tight-fitting caps that shall resist a torque of 4 lbf-in (0.45 N-m) and a tensile force of 15 lbf (67 N) without loosening.

5.3.10 All fasteners shall be corrosion resistant to a level where no rust is evident after a 24-h salt spray test to Practice B117.

5.3.11 No welds shall be made to any steel frame or accessory component with a thickness of less than 0.059 in. (1.5 mm).

5.3.12 No “saddle” welds shall be made to any steel frame or accessory component with a thickness of less than 0.071 in. (1.8 mm). An example of a saddle-welded tee fitting is shown in Fig. 1.

5.3.13 All welded joints shall be rendered corrosion resistant to a level where no rust is evident after a 24-h salt spray test to Practice B117.

5.3.14 No component shall be capable of presenting a protrusion hazard during foreseeable use.

NOTE 1—Test requirements that define a protrusion are in Specification F1487, Subsection 6.3.

5.3.15 There shall be no accessible burrs, sharp points, or sharp edges on tubing when tested in accordance with 16 CFR 1500.48 and 16 CFR 1500.49. End caps or plugs that cannot be

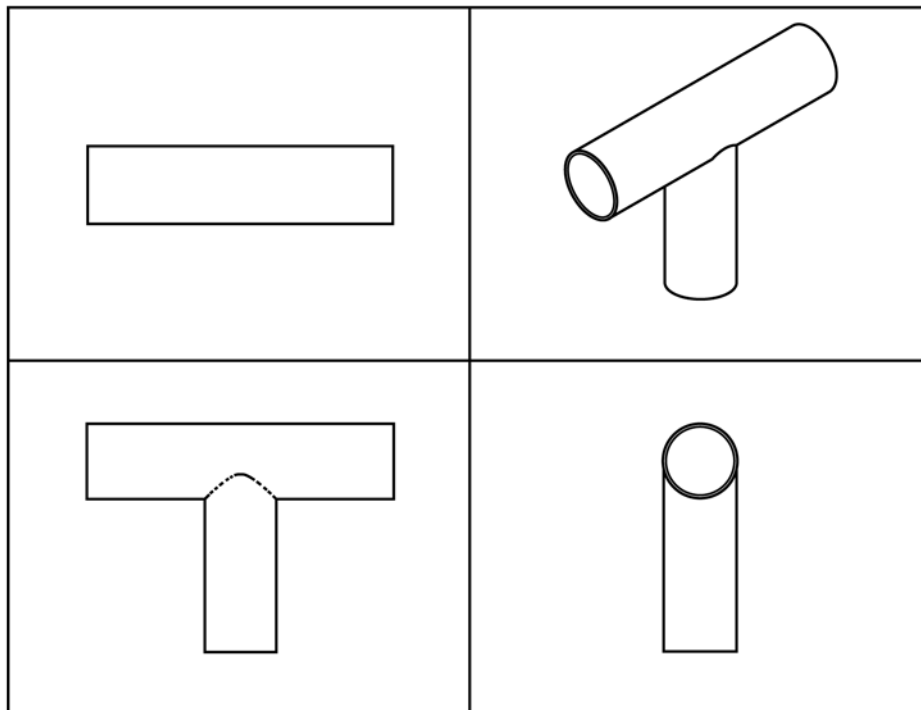

FIG. 1 Saddle Welded Tee Fitting